

This article was downloaded by:

On: 25 January 2011

Access details: *Access Details: Free Access*

Publisher *Taylor & Francis*

Informa Ltd Registered in England and Wales Registered Number: 1072954 Registered office: Mortimer House, 37-41 Mortimer Street, London W1T 3JH, UK



Liquid Crystals

Publication details, including instructions for authors and subscription information:

<http://www.informaworld.com/smpp/title~content=t713926090>

Transient light scattering in helix ferroelectric liquid crystal cells

Valery A. Loiko^a; Alexander V. Konkolovich^a; Alexander A. Miskevich^a

^a Stepanov Institute of Physics of the National Academy of Sciences of Belarus, Minsk, Belarus

To cite this Article Loiko, Valery A. , Konkolovich, Alexander V. and Miskevich, Alexander A.(2009) 'Transient light scattering in helix ferroelectric liquid crystal cells', *Liquid Crystals*, 36: 4, 365 – 370

To link to this Article: DOI: 10.1080/02678290902912827

URL: <http://dx.doi.org/10.1080/02678290902912827>

PLEASE SCROLL DOWN FOR ARTICLE

Full terms and conditions of use: <http://www.informaworld.com/terms-and-conditions-of-access.pdf>

This article may be used for research, teaching and private study purposes. Any substantial or systematic reproduction, re-distribution, re-selling, loan or sub-licensing, systematic supply or distribution in any form to anyone is expressly forbidden.

The publisher does not give any warranty express or implied or make any representation that the contents will be complete or accurate or up to date. The accuracy of any instructions, formulae and drug doses should be independently verified with primary sources. The publisher shall not be liable for any loss, actions, claims, proceedings, demand or costs or damages whatsoever or howsoever caused arising directly or indirectly in connection with or arising out of the use of this material.

Transient light scattering in helix ferroelectric liquid crystal cells

Valery A. Loiko*, Alexander V. Konkolovich and Alexander A. Miskevich

Stepanov Institute of Physics of the National Academy of Sciences of Belarus, Nezalezhnastsi avenue 68, 220072, Minsk, Belarus

(Received 27 January 2009; final form 20 March 2009)

The static model to describe coherent (regular) transmittance in helix ferroelectric liquid crystal cells under the transient light scattering mode is proposed. It can be used to develop three-dimensional volumetric and two-dimensional liquid crystal displays. The dependence of coherent transmittance on cell parameters and the amplitude of the applied electric field is analysed. Conditions for increasing scattering efficiency and contrast ratio enhancement through an interference quenching effect of the coherent transmittance are indicated.

Keywords: liquid crystals; transient light scattering; displays

1. Introduction

Light scattering is one of the promising methods in the development of three-dimensional (3D) volumetric displays (VMDs) (1–3). The multiplanar VMDs produce an image by projecting a series of 2D planar cross-sections of a real scene onto a set of liquid crystal (LC) plates with electrically controlled scattering. They undergo periodic switching with a period equal to or less than the eye's integration time. The light scattering is due to spatial heterogeneity of the LC cell optical anisotropy (1). In the development of multilayered VMDs plates of ferroelectric liquid crystals (FLCs) are used (1–3) to decrease the electro-optic response time.

The spatial heterogeneity of optical anisotropy results from the formation of transient domains at changing FLC orientation structure. Parameters of transient domains (size, shape and internal structure) and their number depend on the properties of FLC, impurity components and the boundary conditions caused by the orienting substrates. Transient domains are texturally observed as strips or spots of variable optical density. Light scattering by transient domains (transient light scattering (TLS)) is a non-stationary dynamic process. In the birefringence mode TLS is the preventing factor decreasing the light modulation efficiency. On the other hand, in the scattering mode the conditions to increase the efficiency of TLS can be provided by special means.

There are several types of light scattering in FLCs, such as light scattering on transient domains in helix and helix-free FLCs, and light scattering on ferroelectric domains in helix-free FLCs (3). Light scattering in FLCs is mainly investigated experimentally. It is important to develop a model for describing light scattering. The model has to take into account the

formation and evolution of transient domains, the change of their internal orientation structure, etc. An important aim in light scattering investigation is to reveal the conditions of high transparency of FLC cells and high scattering efficiency.

In this study, we propose the static optical model of TLS for helix FLC cells. The model is based on the anomalous diffraction (4, 5) and effective medium (6) approaches. The conditions for the control electric field decrease and scattering efficiency increase due to the interference quenching effect (4) of the coherent (regular) part of the transmitted light are indicated.

2. Basic relations

Consider the plane-parallel layer of planar helix SmC* LC. Orientation structure of the SmC* phase is characterised by molecular tilt angle θ (determined with respect to the smectic layer normal) and spontaneous polarisation vector \mathbf{P}_s in the smectic layer planes. The orientation of \mathbf{P}_s on the ferroelectric cone is determined by azimuth angle φ (see Figure 1). Under electric field \mathbf{E} applied normally to the cell, LC molecules rotate to the stable state position and spontaneous polarisation vectors \mathbf{P}_s in smectic layers are oriented in parallel to the direction of the applied electric field \mathbf{E} .

The change of orientation structure of FLC is accompanied by the formation of transient domains with energy-unstable orientation of spontaneous polarisation vectors \mathbf{P}_s . Borders of transient domains move, and are generally deformed under the applied field. The internal structure and number of transient domains are also changed under the applied field. Formation of transient domains leads to the spatial

*Corresponding author. Email: loiko@dragon.bas-net.by

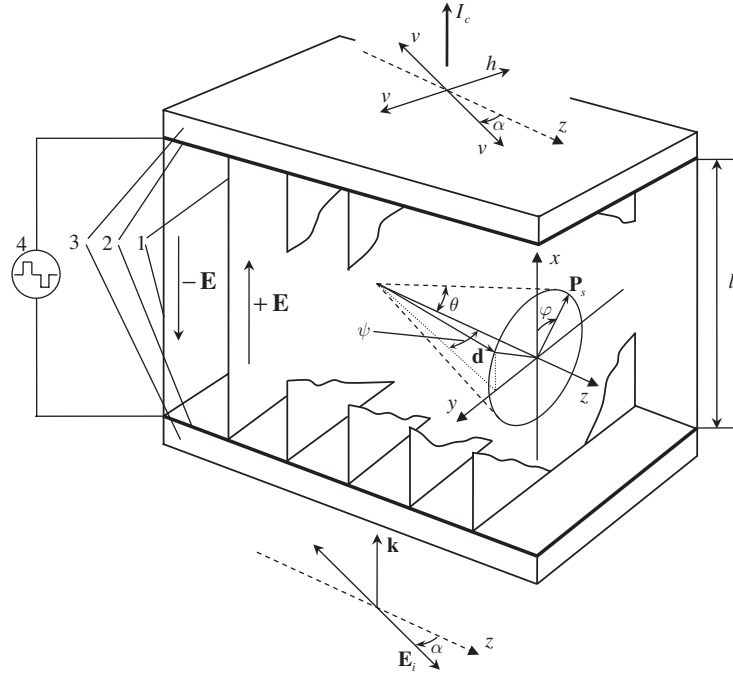

Figure 1. Schematic presentation of the FLC cell and illumination geometry by linearly polarised light; (x, y, z) is the laboratory coordinate system; z is the helix axis; \mathbf{k} and \mathbf{E}_i are the wave vector and polarisation vector of the incident light, respectively; α is the polarisation angle; \mathbf{E} is the vector of the electric field strength; \mathbf{d} is the director (optical axis) in single smectic layer; \mathbf{P}_s is the spontaneous polarisation vector; θ is the tilt angle; ϕ is the helix azimuth angle at rotation of director \mathbf{d} on the ferroelectric cone; ψ is the angle between the principal plane (\mathbf{k}, \mathbf{d}) in the single smectic layer and helix axis z ; lines vv and vh denote the directions of polarisation of the transmitted light parallel and orthogonal to polarisation vector \mathbf{E}_i of the incident light; l is the FLC layer thickness; I_c denotes the coherent (regular) component of the transmitted light. The smectic layers, conducting layers, transparent substrates, and generator of applied electric field are denoted by digits 1, 2, 3, 4, respectively.

heterogeneity of the FLC layer anisotropy and to the dynamic (transient) light scattering. The TLS occurs via arbitrarily located areas with variable optical properties.

The coherent transmission coefficient of the FLC layer can be written in the form (4)

$$T_c = 1 - Q\eta + \frac{Q^2 L}{2} \eta^2, \quad (1)$$

where Q and L stand for parameters describing the scattering by transient domains, and η is the filling coefficient determining the part of layer occupied by transient domains. Parameters Q , L , and η depend on the controlled field E .

For optical parameters Q and L , we write

$$Q = \frac{4\pi}{k^2 \sigma} \text{Re} \langle f_{vv}(0) \rangle, \quad (2)$$

$$\frac{Q^2 L}{2} = \frac{4\pi^2}{k^4 \sigma^2} \left\{ \langle |f_{vv}(0)|^2 \rangle + \langle |f_{vh}(0)|^2 \rangle \right\}, \quad (3)$$

where σ is the cross-section of transient domain in the (y, z) plane of the lab coordinate system (x, y, z) , $k = 2\pi/\lambda$, $\langle f_{vv}(0) \rangle$ and $\langle f_{vh}(0) \rangle$ are mean values of vv - and vh -components of the vector amplitude scattering function at zero scattering angle for polarisations of scattered light parallel and perpendicular to the polarisation vector of the incident light. Angular brackets $\langle \rangle$ indicate the averaging over internal structure of the transient domains.

To analyse coherent (regular) transmittance of the helix FLC layer the anomalous diffraction approach (4, 5) and effective medium approach (6) are used. We model transient domains by ellipsoids stretched in the direction orthogonal to the helix axis. In such a case the averaged components of the vector amplitude scattering function $\langle f_{vv}(0) \rangle$ and $\langle f_{vh}(0) \rangle$ can be written in the form:

$$\langle f_{vw}(0) \rangle = \frac{k^2 \sigma}{\pi} \{ K_e(i\Delta_e^{eff}) \cos^2(\alpha - \psi_{eff}) + K_o(i\Delta_o^{eff}) \sin^2(\alpha - \psi_{eff}) \}, \quad (4)$$

$$\langle f_{vh}(0) \rangle = \frac{k^2 \sigma}{2\pi} \{ K_e(i\Delta_e^{eff}) - K_o(i\Delta_o^{eff}) \} \sin 2(\alpha - \psi_{eff}), \quad (5)$$

where K is the van de Hulst's function (7), α is the polarisation angle (angle between polarisation vector of the incident light \mathbf{E}_i and helix axis z), angle ψ_{eff} determines the coordinate system, where the average dielectric tensor is diagonal (8) (the angle ψ for a single smectic layer is shown in Figure 1), and $\Delta_{e,o}^{eff}$ are the effective phase shifts of extraordinary and ordinary waves on the transient domains,

$$\Delta_{e,o}^{eff} = \frac{2\pi l}{\lambda} (n_{e,o}^{eff} - n_{e,o}). \quad (6)$$

Here, $n_{e,o}^{eff}$ are the extraordinary and ordinary effective refractive indices of transient domains, $n_{e,o}$ are the extraordinary and ordinary refractive indices of FLC in the unwinding state, l is the FLC layer thickness, and λ is the wavelength of incident light.

To find the distribution of the azimuth angle ϕ for transient domains the problem of free energy W minimisation should be solved taking into account physical mechanisms of the domain formation (2):

$$\frac{\partial W}{\partial \varphi} = 0, \quad W \rightarrow W_{\min}, \quad (7)$$

where W_{\min} is the minimal equilibrium value of the volume-free energy density.

On the basis of the minimisation problem for W (9, 10) at deformation of the helix structure under the small applied electric field, the partial solution for the azimuth angle φ can be written as

$$\varphi = \varphi_0 \mp \frac{\pi^2}{8} |E_n^*| \sin \varphi_0. \quad (8)$$

Here, $\varphi_0 = q_0 z$ is the azimuth angle rotation along the helix axis in the absence of the applied field; $q_0 = 2\pi/p_0$; p_0 is the helix pitch; the sign «−» corresponds to $E > 0$; the sign «+» corresponds to $E < 0$ for left-handed FLC (this case is displayed in Figure 1); the sign «+» corresponds to $E > 0$, the sign «−» corresponds $E < 0$ for right-handed FLC; $E_n^* = E/E_{mn}$ is the normalised applied electric field; E_{mn} is the value of applied field when transient domains disappear and the monodomain ferroelectric structure is formed:

$$E_{mn} = \frac{\pi^2 K_\varphi q_0^2}{8 P_s}, \quad (9)$$

where K_φ is the elasticity modulus, determining the director deformation along the azimuth angle ϕ .

The effective refractive indices $n_{e,o}^{eff}$ were found at the uniaxial approximation by the diagonalisation of the average dielectric tensor:

$$(n_{e,o}^{eff})^2 = \varepsilon_{iso} - \frac{\Delta\varepsilon}{3} D_{33,22}. \quad (10)$$

Here $\Delta\varepsilon = n_e^2 - n_o^2$ is the dielectric anisotropy,

$$\varepsilon_{iso} = (2n_o^2 + n_e^2)/3, \quad (11)$$

$$D_{33} = \langle b_{22} \rangle \sin^2 \psi_{eff} + \langle b_{23} \rangle \sin 2\psi_{eff} + \langle b_{33} \rangle \cos^2 \psi_{eff}, \quad (12)$$

$$D_{22} = \langle b_{22} \rangle \cos^2 \psi_{eff} - \langle b_{23} \rangle \sin 2\psi_{eff} + \langle b_{33} \rangle \sin^2 \psi_{eff}. \quad (13)$$

$$\psi_{eff} = \frac{1}{2} \arctan \left(\frac{2\langle b_{23} \rangle}{\langle b_{33} \rangle - \langle b_{22} \rangle} \right), \quad (14)$$

$$\langle b_{22} \rangle = 1 - 3 \sin^2 \theta \langle \cos^2 \varphi \rangle, \quad (15)$$

$$\langle b_{23} \rangle = -\frac{3}{2} \sin 2\theta \langle \cos \varphi \rangle, \quad (16)$$

$$\langle b_{33} \rangle = b_{33} = 1 - 3 \cos^2 \theta, \quad (17)$$

$$\langle \cos^2 \varphi \rangle = \frac{1}{2} (1 + \langle \cos 2\varphi \rangle), \quad (18)$$

$$\langle \cos \varphi \rangle = \frac{2}{\pi} \int_0^\pi \cos \varphi d\varphi_0 = 2J_1 \left(\frac{\pi^2}{8} E_n^* \right), \quad (19)$$

$$\langle \cos 2\varphi \rangle = \frac{2}{\pi} \int_0^\pi \cos 2\varphi d\varphi_0 = 2J_2 \left(\frac{\pi^2}{4} E_n^* \right), \quad (20)$$

where J_1 and J_2 are the cylindrical first- and second-order Bessel's functions of the first kind.

At conditions corresponding to constant local density of the transient domains for the value of filling coefficient η we have found

$$\eta = \frac{1}{1 + \frac{\pi^2}{16} |E_n^*|}. \quad (21)$$

Equations (1)–(21) allow one to analyse the coherent transmission coefficient T_c for the plane-parallel helix FLC cell in the static applied electric field.

To take into account dynamic aspects (hysteresis and relaxation properties) of the orientation structure of FLC the balance equation for volume free energy density should be used (2, 11).

3. Results

Here we present the data obtained on the basis of the derived above equations. Note that formula (8) is derived for small values of the applied field, but it correctly qualitatively describes the deformation of the helix structure at high field values as well (12).

The dependence of coherent transmittance T_c for a helix FLC cell with layer thickness $l = 5\mu\text{m}$, refractive indices of FLC $n_o = 1.5$, $n_e = 1.7$ ($\lambda = 0.6328\mu\text{m}$) in a static electric field is displayed in Figure 2 at different tilt angles θ . Asymmetry of the electro-optical response at the deformed helix FLC structure at positive and negative applied electric fields takes place, when the incident light polarisation angle $\alpha \neq 0$. The

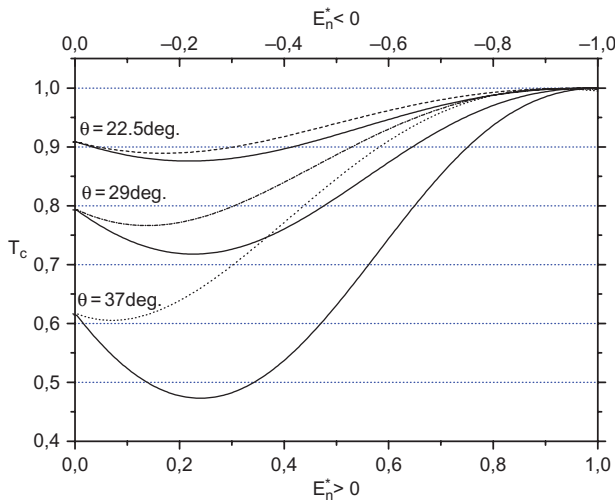

Figure 2. Dependence of coherent transmittance T_c for helix FLC cell on the normalised applied electric field E_n^* at different tilt angles θ . The layer thickness $l = 5\mu\text{m}$; the FLC refractive indices $n_e = 1.7$, $n_o = 1.5$; the polarisation angle $\alpha = \theta$. Solid lines correspond to positive electric field. Dashed lines correspond to negative field.

asymmetry increases with increasing tilt angle θ . At $\alpha = \theta$ the maximal asymmetry of electro-optical response is achieved.

The dependence of the modulation depth

$$\Delta T_c = T_c(-E_n^*) - T_c(+E_n^*) \quad (22)$$

on the polarisation angle α is shown in Figure 3. The maximal value of $|\Delta T_c|$ takes place at $|\alpha| = \theta = 45^\circ$.

Dependence of coherent transmission coefficient T_c on applied electric field E can be monotonic (so-called ‘S-formed response’) or non-monotonic (‘anomalous’ response with minimum (see Figure 2)). The number of extremes on the $T_c = T_c(E)$ -dependence is determined by optical parameters Q , L and filling coefficient η . Dependence of coherent transmittance T_c in positive and negative applied fields if several extremes are implemented is displayed in Figure 4.

The results of calculation for contrast ratio (CR), defined as:

$$CR = T_c(E_n^* = 1)/T_c(E_n^*). \quad (23)$$

and are displayed in Figure 5.

Under certain conditions the interference quenching effect ($T_c = 0$) can be implemented in a helix ferroelectric liquid crystal cell. This effect takes place (see Equation (1)) if parameter $L = 1/2$ and filling coefficient $\eta = 2/Q$ (see (4, 13)). In such a case the dramatic increase in TLS efficiency and contrast ratio enhancement due to the quenching effect can be realised.

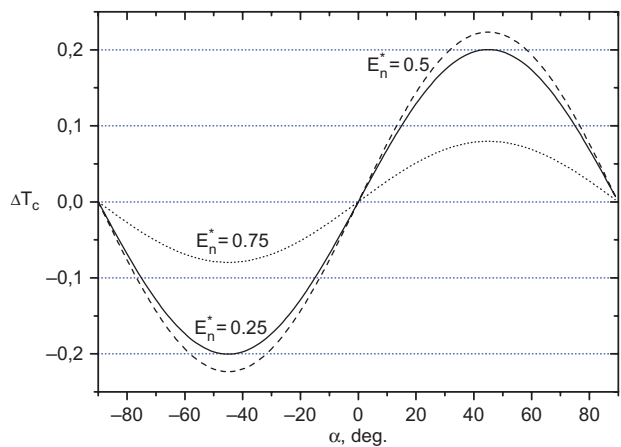

Figure 3. Dependence of the modulation depth $\Delta T_c = T_c(-E_n^*) - T_c(+E_n^*)$ on polarisation angle α of the incident light at different values of normalised applied field E_n^* . The layer thickness $l = 5\mu\text{m}$; the FLC refractive indices $n_e = 1.7$, $n_o = 1.5$; $\alpha = \theta = 37^\circ$.

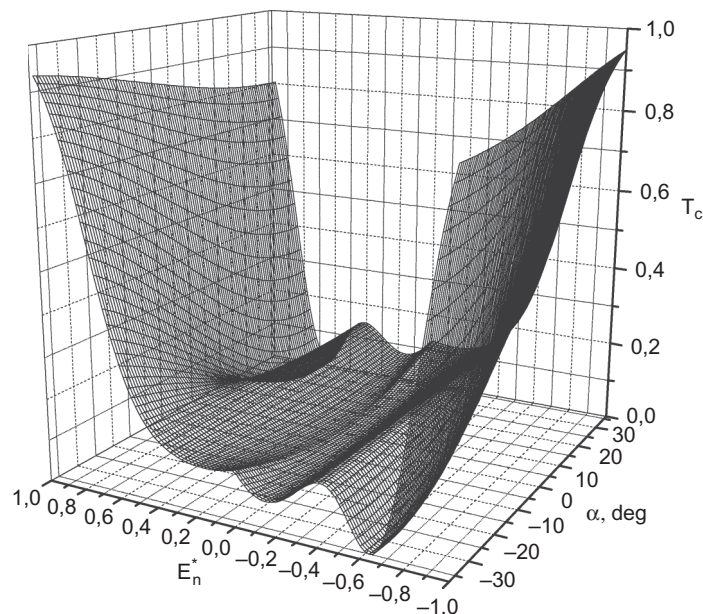

Figure 4. Dependence of the coherent transmittance T_c for helix FLC cell on normalised applied field E_n^* and polarisation angle α . The FLC layer thickness $l = 13\mu\text{m}$; the refractive indices $n_e = 1.7$, $n_o = 1.5$; the tilt angle $\theta = 37^\circ$.

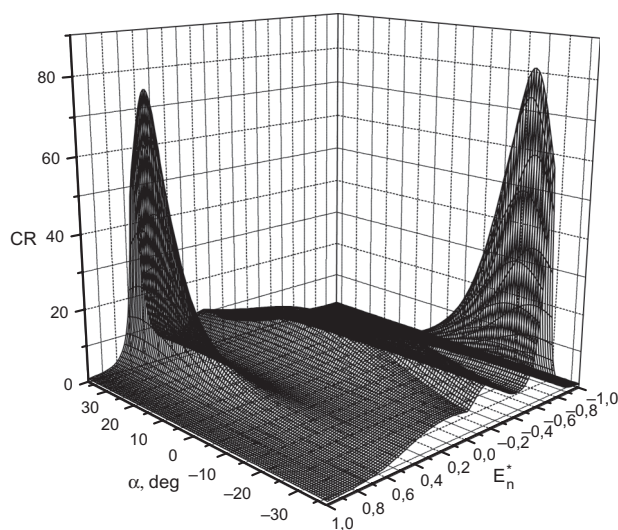

Figure 5. Dependence of the contrast ratio CR for helix FLC cell on normalised applied field E_n^* and polarisation angle α . The FLC layer thickness $l = 13\mu\text{m}$; the refractive indices $n_e = 1.7$, $n_o = 1.5$; the tilt angle $\theta = 37^\circ$.

4. Conclusions

The proposed model enables calculation of the coherent transmittance for the plane-parallel cells of helix FLC operated in TLS mode.

The model can be extended to solve the following problems:

- (i) to find conditions of TLS efficiency increase at reduced driving voltage;

- (ii) to investigate polarisation and spectral dependencies of electro-optical response in FLC cells taking into account the incoherent (diffuse) component of the scattered light;
- (iii) to analyse 2D modulated FLC structures to obtain polarisation-independent electro-optical modulation of transmitted light.

The obtained results can be useful for 3D volumetric and 2D liquid crystal displays development.

Acknowledgement

This research is supported by Fund of Basic Research of Belarus Grant F08R-044.

References

- (1) Andreev, A.L.; Bobylev, V.P.; Gonchakov, S.A.; Kompanets, I.N.; Lasarevu, B.; Pozhidaev, E.P.; Shoshin, V.M. Proceedings of the Conference "Vehicle Display' 04", Detroit, MI, 2004.
- (2) Andreev, A.L.; Bobylev, V.P.; Fedosenkova, T.B.; Yambaev, I.B.; Kompanets, I.N.; Pozhidaev, E.P.; Shoshin, V.M.; Shumkina, Y.P. *J. Soc. Info. Display* **2006**, *14*, 643–648.
- (3) Andreev, A.L.; Bobylev, V.P.; *Opt. J.* **2005**, *72*, 58–65.
- (4) Loiko, V.A.; Konkolovich, A.V. *J. Phys. D: Appl. Phys.* **2000**, *33*, 2201–2210.
- (5) Loiko, V.A.; Konkolovich, A.V. *J. Opt. B: Quantum Semiclass. Opt.* **2001**, *3*, S155–S158.
- (6) Loiko, V.A.; Konkolovich, A.V.; Miskevich, A.A. *Phys. Rev. E.* **2006**, *74*, 031704-1–031704-7.

- (7) van de Hulst, H.C. *Light Scattering by Small Particles*; Wiley: New York, 1957.
- (8) Abdulhalim, I.; Moddel, G. *Mol. Cryst. Liq. Cryst.* **1991**, *200*, 79–101.
- (9) Ostrovskii, B.I.; Pikin, S.A.; Chigrinov, V.G. *J. Exp. Theor. Phys.* **1979**, *77*, 1615–1625.
- (10) Pikin, S.A.; Indenbom, V.L. *Ferroelectrics* **1978**, *20*, 151–153.
- (11) Kiselev, A.D.; Chigrinov, V.G.; Pozhidaev, E.P. *Phys. Rev. E.* **2007**, *75*, 061706C-1–061706-15.
- (12) Beresnev, L.A.; Chigrinov, V.G.; Dergachev, D.I.; Pozhidaev, E.P.; Funfschilling, J.; Schadt, M. *Liq. Cryst.* **1989**, *5*, 1171–1177.
- (13) Ivanov, A.P.; Loiko, V.A.; Dick V.P. *Propagation of Light in Densely Packed Dispersed Media*. Nauka i tehnika: Minsk, Belarus, 1988.